

# RP- 80

## Pressure Switch Installation Manual

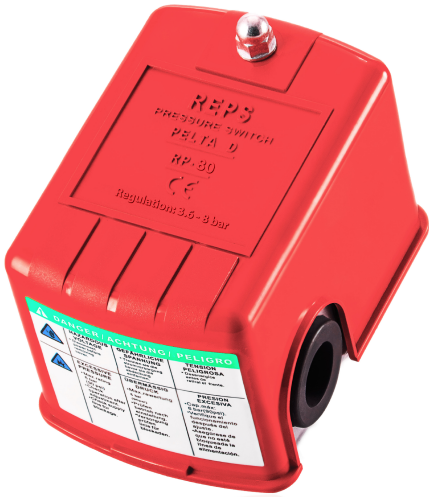

### Information Leaflet Pressure Switch Instructions

### Prospecto de la información Instrucciones para el Interruptor de Presión

### Feuillet de l'information Directives concernant le manostat

#### Pressure Switch Instructions

1. If applicable, disconnect power to the pump.
2. Remove cover from switch by loosening the thumbscrew at the top of the pressure switch.
3. Connect the plumbing connection to the bottom of the pressure switch.
4. Feed pump motor wires through opening in the pressure switch and secure with a locknut.

#### ⚠ WARNING

**FOR PROPER GROUND, PRESSURE SWITCH MUST MAKE METAL-TO-METAL CONTACT WITH THE MOTOR.**

5. Terminate the two motor wires to the pressure switch at connections marked LOAD.
6. Terminate the motor ground wire to one of the green ground screws at the bottom of the pressure switch.
7. Feed incoming wires through opening in the switch (opposite side of the motor wires) and secure with a locknut.
8. Terminate the two incoming wires to the pressure switch at connections marked LINE.
9. Terminate the incoming ground wire to the remaining unused green ground screw at the bottom of the pressure switch.
10. **Adjusting:** This product has been set to certain pressure when it is produced (see the label on inner cover). Pressure tolerance in both cut-in and cut-out is  $\pm 1.4$  BAR. If the user wants to adjust the pressure by himself, see **Figure 1**.

**Note:** 15 inch-pounds maximum tightening torque on field wiring screws.

**Cut-in:** Turn major nut (#1) clockwise for higher cut-in pressure, or counter-clockwise for lower cut-in pressure.

**Cut-out:** Turn minor nut (#2) clockwise for higher cut-out pressure, or counter-clockwise for lower cut-out pressure.

11. Re-attach switch cover.

#### Instrucciones para el Interruptor de Presión

1. Si corresponde, desconecte la alimentación hacia la bomba.
2. Retire la tapa del interruptor, al aflojar el tornillo de mariposa en la parte superior del interruptor de presión.
3. Lleve acabo la conexión de plomería en la parte inferior del interruptor de presión.
4. Alimente los cables del motor de la bomba al abrir el interruptor de presión y sujetelo con una tuerca de seguridad.

#### ⚠ ADVERTENCIA

**PARA UN A CONEXIÓN APROPIADA A TIERRA, EL INTERRUPTOR DE PRESIÓN DEBE HACER CONTACTO DE METAL A METAL CON EL MOTOR.**

5. Conecte los dos cables del motor con el interruptor de presión en el punto de conexión marcado como LOAD (Carga).
6. Conecte los cables de tierra del motor con uno de los tornillos verdes de tierra, en la parte inferior del interruptor de presión.
7. Inserte los cables entrantes a través de la abertura en el interruptor (lado opuesto de los cables del motor) y asegúrelos con una tuerca de seguridad.
8. Conecte los dos cables entrantes con el interruptor de presión en los puntos de conexión marcados como LINE (Linea).
9. Conecte los cables de tierra entrantes con uno de los tornillos verdes restantes de tierra que no se haya utilizado, en la parte inferior del interruptor de presión.
10. **Ajuste:** Este producto se ha establecido para cierta presión, cuando ésta se produce (vea la etiqueta en la cubierta interior). La tolerancia de presión tanto al cerrar el paso como al liberarlo es  $\pm 20$  PSI  $\pm$  (1.4 BAR). En caso de que el usuario desee ajustar la presión, consulte **Figura 1**.

**Nota:** 15 in lbs. (15 pulg/libra) de torsión máxima de apriete en tornillos de cableado de campo.

**Cierre de presión:** Gire la tuerca mayor (1) a la derecha para lograr una presión mayor o a la izquierda para una presión menor.

**Apertura de presión:** Gire la tuerca menor (2) a la derecha para lograr una presión mayor o a la izquierda para una presión menor.

11. Vuelva a fijar la tapa del interruptor.

#### Directives concernant le manostat

1. Si applicable, débranchez l'alimentation de la pompe.
2. Enlever le couvercle du manostat en desserrant la vis à oreilles au-dessus du manostat.
3. Branchez le raccord de plomberie au bas du manostat.
4. Insérez les fils du moteur de la pompe à travers l'ouverture du manostat et maintenez-les en position avec un contre-écrou.

#### ⚠ AVERTISSEMENT

**POUR ASSURER UNE BONNE MISE À LA TERRE, LE MANOSTAT DOIT ÊTRE EN CONTACT MÉTAL À MÉTAL AVEC LE MOTEUR.**

5. Raccordez les deux fils du moteur aux bornes portant la mention « LOAD » (charge) du manostat.
6. Raccordez le fil de mise à la terre du moteur à l'une des vis de mise à la terre vertes au bas du manostat.
7. Insérez les fils de l'alimentation à travers l'ouverture du manostat (côté opposé des fils du moteur)
8. Raccordez les deux fils de l'alimentation aux bornes portant la mention « LINE » (ligne) du manostat.
9. Raccordez le fil de mise à la terre de l'alimentation à la vis de mise à la terre verte inutilisée au bas du manostat.
10. Réglage : ce produit a été réglé à une certaine pression lors de sa fabrication (voir l'étiquette sur le couvercle intérieur). Les tolérances de pression pour l'enclenchement et le déclenchement sont de  $\pm 20$  PSI  $\pm$  (1.4 BAR). Si l'utilisateur désire régler la pression par lui-même, se **Figure 1**.

**Remarque :** Couple de serrage maximum de 15 lb/po. pour tous les raccords effectués au chantier.

**Enclenchement :** Tournez le gros écrou (1) dans le sens horaire pour une pression d'enclenchement plus élevée ou dans le sens antihoraire pour une pression d'enclenchement moins élevée.

**Déclenchement :** Tournez le petit écrou (2) dans le sens horaire pour une pression de déclenchement plus élevée ou dans le sens antihoraire pour une pression de déclenchement moins élevée.

11. Remettez le couvercle du manostat en place avec la vis.

# Wiring Diagram

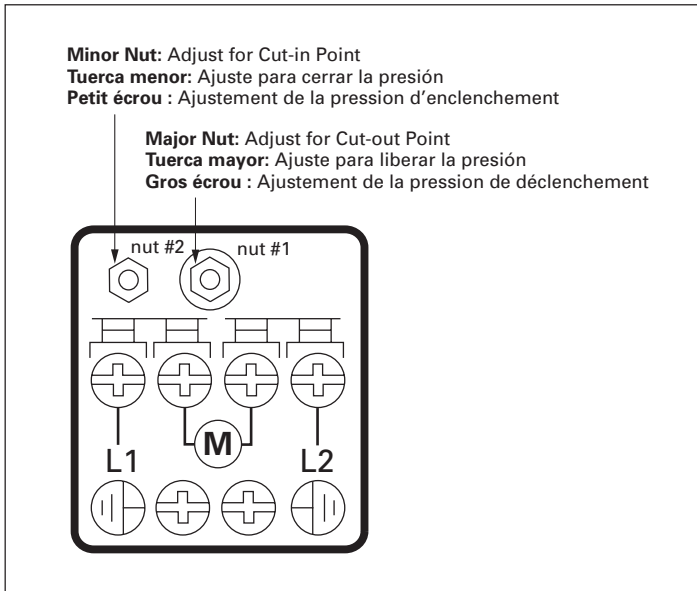

Figure 1. Wiring Diagram  
 Figura 1. Diagrama eléctrico  
 Figure 1. Diagramme de câblage

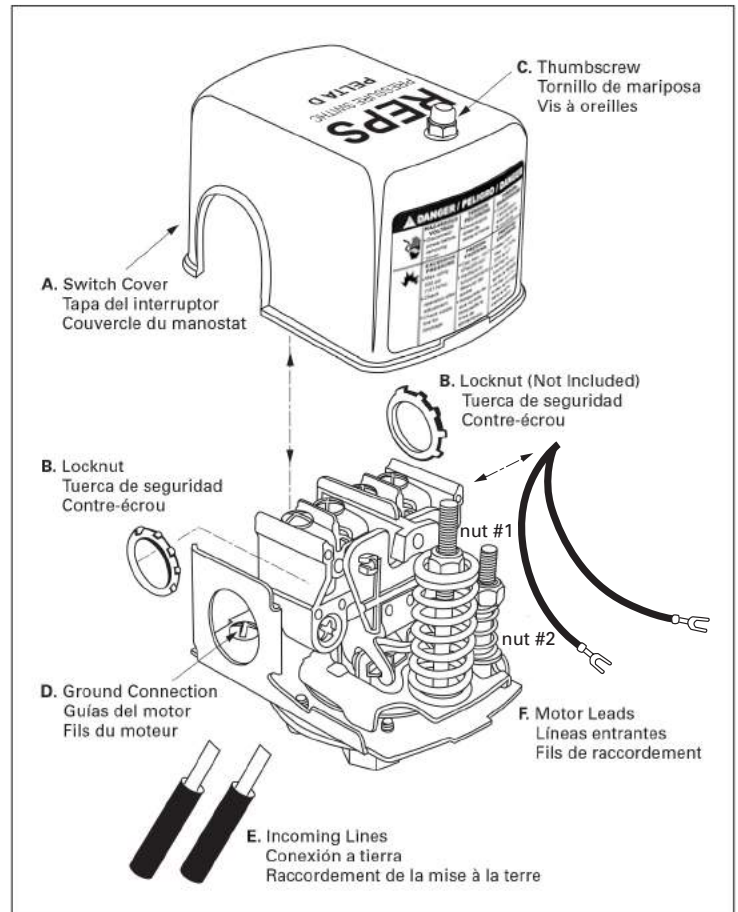
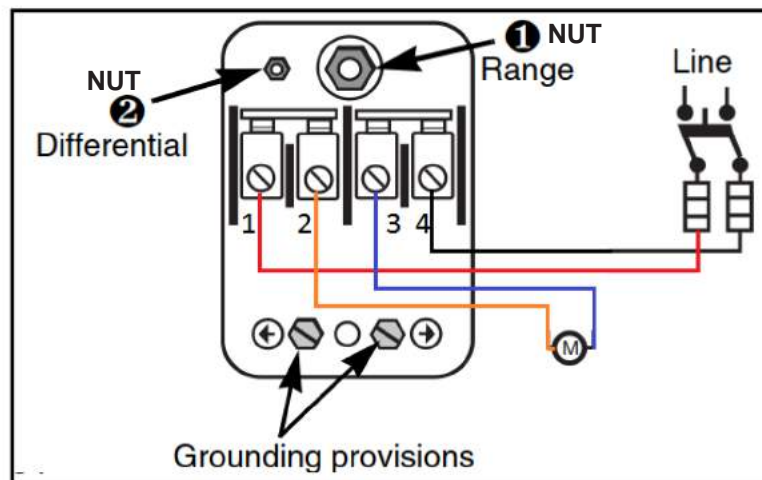

Figure 2. Parts Drawing  
 Figura 2. Dibujo de las piezas  
 Figure 2. Dessin de pièces



# Piping Models



## How to Adjust the "RP- 80" on a Pump



A pump uses a pressure-activated regulator to maintain water pressure. The regulator operates within a factory-specified range, activating the pump as pressure drops and stopping the pump when the pressure rises to a set level. You can make minor adjustments to the pressure regulator with a nut driver. Adjusting the pressure regulator is easy and should only take a couple of minutes.

### **Step 1**

Turn off the breaker that powers the well pump. Turn the nut on top of the regulator cover cover counterclockwise to remove it. Pull the cover off the regulator and set the cover aside.

### **Step 2**

Locate the large nut and spring on the regulator. Turn the nut clockwise with a nut driver to raise the total range of pressure provided by the regulator.

### Step 3

Turn the nut counterclockwise with a nut driver to reduce the total range of pressure provided by the regulator.

### Step 4

Locate the small nut and spring on the regulator. Turn the nut clockwise with a nut driver to reduce the difference between the "cut in" and "cut out" pressures.

### Step 5

Turn the nut counterclockwise to increase the difference.

### Step 6

Put the regulator cover on the regulator, place the nut on the threaded rod and tighten it with a nut driver.

### Point

Make small adjustments to the pressure and check the pressure after each adjustment. Turning the large nut changes the overall range higher or lower. A regulator that operates in a range from 50 to 70 psi may operate at 60 to 80 psi if the nut is turned clockwise or 40 to 60 psi if it's turned counterclockwise. Turning the small nut widens or narrows the total operating range. A regulator that operates at 50 to 70 psi may operate at 55 to 65 psi if the nut is turned clockwise or 45 to 75 psi if it's turned counterclockwise.

### **Warning**

Never attempt to adjust the regulator while the power to the pump is on. Don't adjust the regulator outside of the rated range of the pump and associated equipment.

# **"PELTA D" Pump Pressure Switch Instructions**

---

Pressure switches for water well pumps use a double-spring type switch. One spring is for the cut in pressure and the other is for the cut out pressure. Typical pressure settings for a low-pressure system will be a cut in (start pressure) of 54 PSI and a cut out (stop pressure) of 75 PSI. A higher-pressure system will use a cut in pressure of 64 PSI and a cut out of 85 PSI. When adjusting any pressure switch, you must have a pressure gauge installed on the water system.

## **Safety and Identification of a "PELTA D" Pressure Switch**

Pull the plastic cover from the pressure switch by removing the single nut on top of the cover. Be aware that there are live electrical parts within easy reach on the pressure switch. Use a wrench that fits the two small nuts on top of the two springs. Typically, one nut size is a 7/16 inch and the other is either a 3/8 inch or 1/2 inch wrench. The larger of the two springs, called "nut #1," is used for raising and lowering the cut in and cut off pressure. The smaller nut and spring, called "nut #2," is used for widening the gap of the cut off pressures. The smaller spring will raise or lower the gap or pressure difference of the pump turning off. That pressure difference will fall in the range from 1 PSI generally up to 50 PSI. The larger spring raises and lowers the overall pressure of that gap.

## **Adjust the Big Spring Nut #1**

Turn the nut on top of the large spring to raise the cut in and cut off pressures. Open a water faucet and watch the pressure gauge. Under a normally set pressure switch, the pump should come on at 54 PSI and shut off at 75 PSI. If the pump is starting and stopping at too low a pressure, turn the larger nut clockwise. Adjust just a little at a time and allow the pump to operate. The large nut adjustment is the easiest adjustment to make on the switch.

## Set the Pressure Differential Nut #2

Turning the smaller nut and spring will adjust the upper end cut off pressure. Moving the nut in a clockwise direction will raise the upper limit of the pumps operation. Turning the nut in a counter clockwise direction will lower that overall cut off pressure. Exercise caution when adjusting this setting. If the nut is too loose, the pump will never shut off because the cut in and cut off pressures are too close together.

## The Actual Instructions

The actual instructions printed on the underside of the cover are:  
Turn Nut #1 clockwise to raise both the cut in and cut off pressures.  
Turn Nut #2 clockwise to raise cut off pressure only.

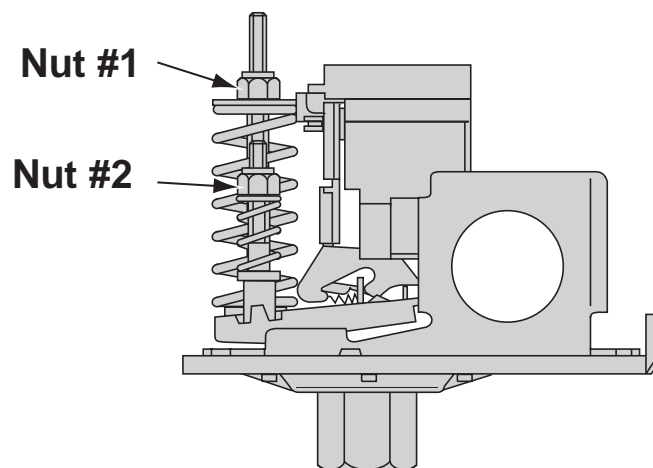

# PRESSURE SWITCH



[www.repsglobal.co.uk](http://www.repsglobal.co.uk)  
[Info@repsglobal.co.uk](mailto:Info@repsglobal.co.uk)

